



PRODAJA, MONTAŽA, OBNOVA IN SERVIS VSEH VRST DVIGAL DVIGALA BARTOL d.o.o.

Badjurova ulica 22, 1000 Ljubljana, Slovenija, Mob: 041/668 069, Tel. 01/4288 645, Fax: 01/4272 858, E-mail: dvlgala-bartol@siol.net, www.dvigala-bartol.eu

Dvojno dvigalo, model CPE 100-2

Kapaciteta: 10000 kg

Model CPE 100-2 je sestavljen iz dveh enot CPE 50-2. Povezani sta z ogrodjem. Na voljo so obešalni kavelj, verižno gnani ali električni mački. Varnostna mejna stikala za najvišji in najnižji položaj kavlja so standardno vgrajena. Nizka krmilna napetost (42 V) je standard.

Možnosti

- Bremenska veriga iz nerjavnega jekla.
- Žakelj za verigo.
- Druge delovne napetosti.
- Motor z zavoro iz nerjavnega jekla.
- Radijsko daljinsko upravljanje.
- Sistem kablov z več obešali.



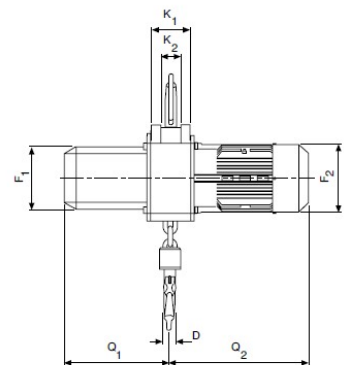
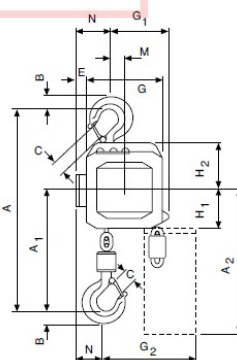
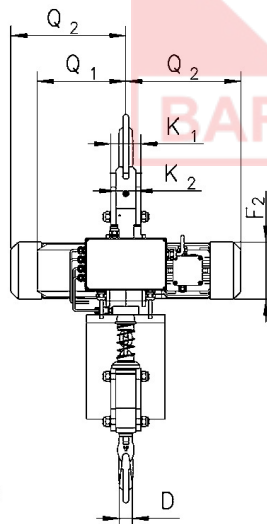
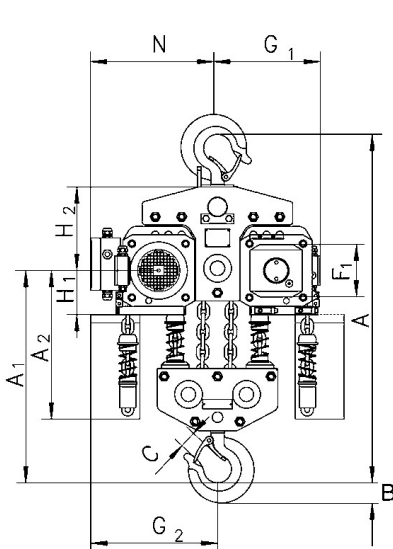
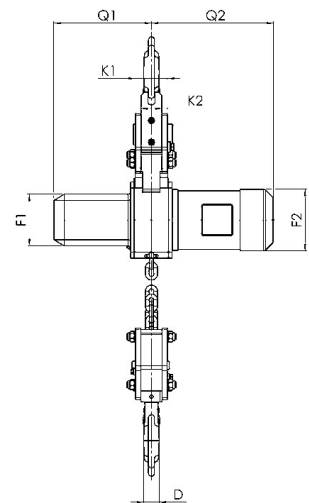
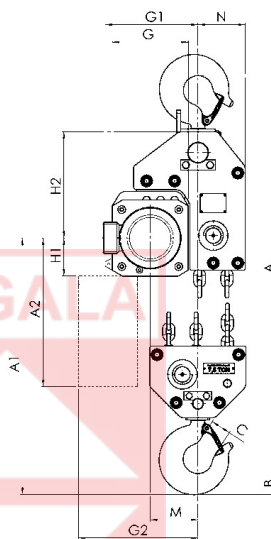
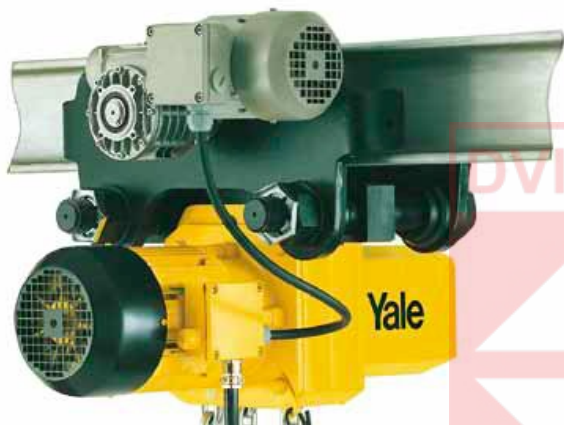
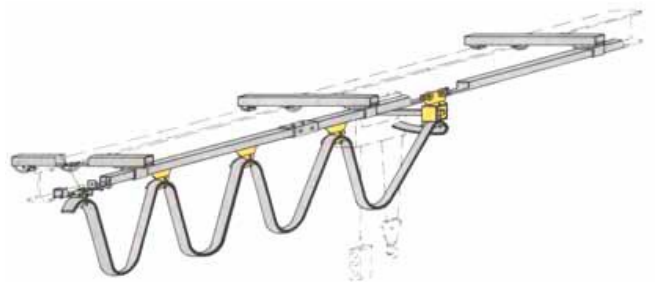

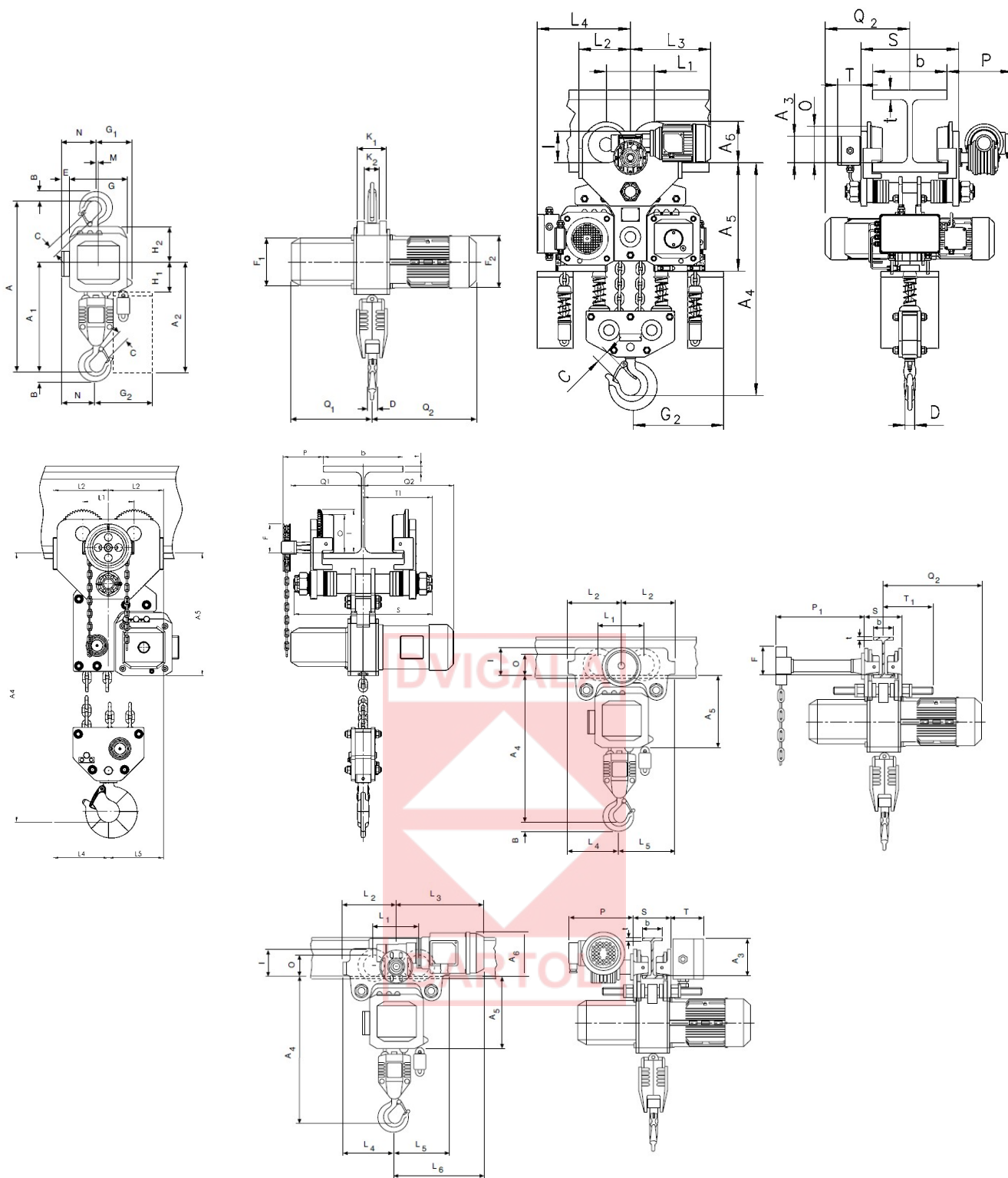

Tehnični podatki, model CPE/CPEF

Model	EAN-No. 4025092*	Nosilnost v kg/ število dvižnih verig	Dimenzije verige d x p mm	Klasifikacija FEM/ISO	Dvižna hitrost za glavni dvig m/min	Dvižna hitrost za fini dvig m/min	Motor dvigala kW	Obratovalni cikel motorja ED %
CPE 16-8	*073240	1600/1	11 x 31	1 Am/M4	8	–	2,3	40
CPEF 16-8	*073257	1600/1	11 x 31	1 Am/M4	8	2	2,3/0,58	40/20
CPE 20-8	*073264	2000/1	11 x 31	1 Bm/M3	8	–	2,8	25

DVIGALA BARTOL d.o.o. Badjurova ulica 22, 1000 Ljubljana, Slovenija, Mob: 041/668 069,
Tel. 01/4288 645, Fax: 01/4272 858, E-mail: dvlgala-bartol@siol.net, www.dvigala-bartol.eu

Za morebitne napake v Slovenskih prospektih ne odgovarjamo!

Model	EAN-No. 4025092*	Nosilnost v kg/ število dviznih verig	Dimenzije verige d x p mm	Klasifikacija FEM/ISO	Dvižna hitrost za glavni dvig m/min	Dvižna hitrost za fini dvig m/min	Motor dvigala kW	Obratovalni cikel motorja ED %
CPEF 20-8	*073271	2000/1	11 x 31	1 Bm/M3	8	2	2,8/0,7	25/15
CPE 25-5	*073288	2500/1	11 x 31	1 Am/M4	5	-	2,3	40
CPEF 25-5	*073295	2500/1	11 x 31	1 Am/M4	5	1,25	2,3/0,58	40/20
CPE 30-5	*073301	3000/1	11 x 31	1 Bm/M3	5	-	2,8	25
CPEF 30-5	*073318	3000/1	11 x 31	1 Bm/M3	5	1,25	2,8/0,7	25/15
CPE 32-4	*073325	3200/2	11 x 31	1 Am/M4	4	-	2,3	40
CPEF 32-4	*073332	3200/2	11 x 31	1 Am/M4	4	1	2,3/0,58	40/20
CPE 40-4	*073349	4000/2	11 x 31	1 Bm/M3	4	-	2,8	25
CPEF 40-4	*073356	4000/2	11 x 31	1 Bm/M3	4	1	2,8/0,7	25/15
CPE 50-2	*073363	5000/2	11 x 31	1 Am/M4	2,5	-	2,3	40
CPEF 50-2	*073370	5000/2	11 x 31	1 Am/M4	2,5	0,6	2,3/0,58	40/20
CPE 75-1,6	*079907	7500/3	11 x 31	1 Am/M4	1,6	-	2,8	40
CPEF 75-1,6	*079914	7500/3	11 x 31	1 Am/M4	1,6	0,4	2,8/0,58	40/20
CPE 100-2	*060585	10000/4	11 x 31	1 Am/M4	2,5	-	2 x 2,3	40
CPEF 100-2	*060592	10000/4	11 x 31	1 Am/M4	2,5	0,6	2 x 2,3/0,58	40/20

Model	Teža* kavelj za obešanje kg	Teža* s potisnim mačkom kg	Teža* z verižno gnanim mačkom kg	Teža* z električnim mačkom** kg
CPE 16-8	88	150	154	164
CPEF 16-8	93	155	159	169
CPE 20-8	88	150	154	164
CPEF 20-8	93	155	159	169
CPE 25-5	88	150	154	164
CPEF 25-5	93	155	159	169
CPE 30-5	88	150	154	164
CPEF 30-5	93	155	159	169
CPE 32-4	107	169	173	182
CPEF 32-4	112	174	178	187
CPE 40-4	107	169	173	182
CPEF 40-4	112	174	178	187
CPE 50-2	107	169	173	182
CPEF 50-2	112	174	178	187
CPE 75-1,6***	220	320	320	340
CPEF 75-1,6	226	326	326	346
CPE 100-2	282	-	385	406
CPEF 100-2***	287	-	390	411

* Teža pri standardni višini dviga (3 m). Druge višine dviga po naročilu.

** Dodatna teža za dvohitrostno izvedbo znaša 2,0 kg

*** Varnostna mejna stikala za najvišji in najnižji položaj kavlja – 42-voltno nizkonapetostno krmiljenje.

Tehnični podatki mačkov

DVIGALA BARTOL d.o.o. Badjurova ulica 22, 1000 Ljubljana, Slovenija, Mob: 041/668 069, Tel. 01/4288 645, Fax: 01/4272 858, E-mail: dvlgala-bartol@siol.net, www.dvigala-bartol.eu

Za morebitne napake v Slovenskih prospektih ne odgovarjamo!

Nosilnost kg	Velikost	Širina pasnice tekalnega profila b mm	Maks. debelina pasnice tekalnega profila t mm	Min. polmer zavojev m	Hitrost pomikanja električnega mačka m/min pri 50 Hz	Moč motorja električnega mačka kW pri 50 Hz
1600 - 5000	A	98 - 180	27	2.0	11 or 11/2,8	0,37 or 0,3/0,09
1600 - 5000	B	180 - 300	27	1.8	11 or 11/2,8	0,37 or 0,3/0,09
7500 - 10000	B	125 - 310	40	1.8	5 or 5/1,25	0,55 or 0,55/0,12

Dimenzije, model CPE/CPEF

Model	CPE/CPEF 16-8	CPE/CPEF 20-8	CPE/CPEF 25-5	CPE/CPEF 30-5	CPE/CPEF 32-4	CPE/CPEF 40-4	CPE/CPEF 50-2	CPE/CPEF 75-1,6	CPE/CPEF 100-2
A, mm	516	516	516	516	681	681	681	950	1068
A1, mm	286	286	286	286	428	428	428	479	651
A2 (13 m), mm	430	430	430	430	430	430	430	-	-
A2 (13 m), mm	530	530	530	530	530	530	530	530	555
B, mm	35	35	35	35	45	45	45	60	60
C, mm	37	37	37	37	46	46	46	52	52
D, mm	24	24	24	24	30	30	30	40/45	40/45
E, mm	24	24	24	24	24	24	24	-	-
F1, mm	160	160	160	160	160	160	160	160	160
F2, mm	178	178	178	178	178	178	178	178	178
G, mm	220	220	220	220	220	220	220	220	-
G1, mm	180	180	180	180	140	140	140	268	315
G2(13 m), mm	257	257	257	257	218	218	218	-	-
G2(21 m), mm	277	277	277	277	238	238	238	345	408
H1, mm	110	110	110	110	110	110	110	110	135
H2, mm	135	135	135	135	135	135	135	307	256
K1, mm	100	100	100	100	100	100	100	92	92
K2, mm	51	51	51	51	51	51	51	62	62
M, mm	50	50	50	50	10	10	10	138	-
N, mm	84	84	84	84	124	124	124	136	390
Q1, mm	280	280	280	280	280	280	280	280	280
Q2 (CPE), mm	362	362	362	362	362	362	362	362	362
Q2 (CPEF), mm	417	417	417	417	417	417	417	417	417

Dimenzije, model CPE/CPEF

Model	CPE/CPEF 16-8	CPE/CPEF 20-8	CPE/CPEF 25-5	CPE/CPEF 30-5	CPE/CPEF 32-4	CPE/CPEF 40-4	CPE/CPEF 50-2	CPE/CPEF 75-1,6	CPE/CPEF 100-2
A3, mm	121	121	121	121	121	121	121	-	110
A4, mm	465	465	465	465	615	615	615	855	965
A5, mm	298	298	298	298	298	298	298	477	450
A6, mm	178	178	178	178	178	178	178	-	170
b, mm	A = 98 - 180/ B = 180 - 300	A = 98 - 180/ B = 180 - 300	A = 98 - 180/ B = 180 - 300	A = 98 - 180/ B = 180 - 300	A = 98 - 180/ B = 180 - 300	A = 98 - 180/ B = 180 - 300	A = 98 - 180/ B = 180 - 300	125 - 310	125 - 310
F, mm	150	150	150	150	150	150	150	113	113
I, mm	142,5	142,5	142,5	142,5	142,5	142,5	142,5	170	170
L1, mm	209	209	209	209	209	209	209	200	200
L2, mm	262,5	262,5	262,5	262,5	262,5	262,5	262,5	215	215
L3 (VTE), mm	292	292	292	292	292	292	292	-	335
L3 (VTEF), mm	296	296	296	296	296	296	296	-	335

DVIGALA BARTOL d.o.o. Badjurova ulica 22, 1000 Ljubljana, Slovenija, Mob: 041/668 069,
Tel. 01/4288 645, Fax: 01/4272 858, E-mail: dvlgala-bartol@siol.net, www.dvigala-bartol.eu

Za morebitne napake v Slovenskih prospektih ne odgovarjamo!

Model	CPE/CPEF 16-8	CPE/CPEF 20-8	CPE/CPEF 25-5	CPE/CPEF 30-5	CPE/CPEF 32-4	CPE/CPEF 40-4	CPE/CPEF 50-2	CPE/CPEF 75-1,6	CPE/CPEF 100-2
L4, mm	213	213	213	213	253	253	253	215	390
L5, mm	312	312	312	312	272	272	272	215	215
L6 (VTE), mm	342	342	342	342	342	342	342	–	–
L6 (VTEF), mm	346	346	346	346	306	306	306	–	–
O, mm	125	125	125	125	125	125	125	150	150
P (VTE), mm	197	197	197	197	197	197	197	–	273
P (VTEF), mm	205	205	205	205	205	205	205	–	280
P1, mm	229	229	229	229	229	229	229	–	110
S, mm	b + 70	b + 70	b + 70	b + 70	b + 70	b + 70	b + 70	b + 98	b + 98
T, mm	94	94	94	94	94	94	94	–	94
tmax., mm	27	27	27	27	27	27	27	40	40

Sisteme kablov z več obešali najdete na straneh 138—139.

Napravo je certificiralo strokovno združenje (Berufsgenossenschaft); izpolnjujejo tudi zahteve smernic za stroje 2006/42/EG.

Vse nosilnosti in hitrosti, na voljo za standardni model CPE, so na voljo tudi pri izvedbi CPE LH.

Dvigala in mački podjetja Yale niso namenjeni dviganju oseb in se jih v ta namen ne sme uporabljati.

Sisteme kablov z več obešali najdete na straneh 138—139.

